

JUNKIN SAFETY

LIMITED WARRANTY

Junkin Safety Appliance Co warrants their cots to be free from defects in material and workmanship for one year from the date of purchase. This warranty does not apply to cots, which have been abused, misused or modified. If a **Junkin Safety** cot proves to be defective in material and workmanship within one year after purchase, return it to **Junkin Safety** with **Pre-approved shipping instructions**. Please enclose your name, address and phone number with a short description of the problem. **Junkin Safety** will cover freight and at their option, repair or replace defective parts free of charge. Repairs are warranted as described above for the remainder of the original warranty period. **Junkin Safety's** sole liability and your exclusive remedy under this warranty is limited to repair of the defective cot. There are no other warranties expressed or implied and **Junkin Safety** shall not be liable for incidental, consequential or special damages, or any other damages costs or expense of repair or replacement as describer above.

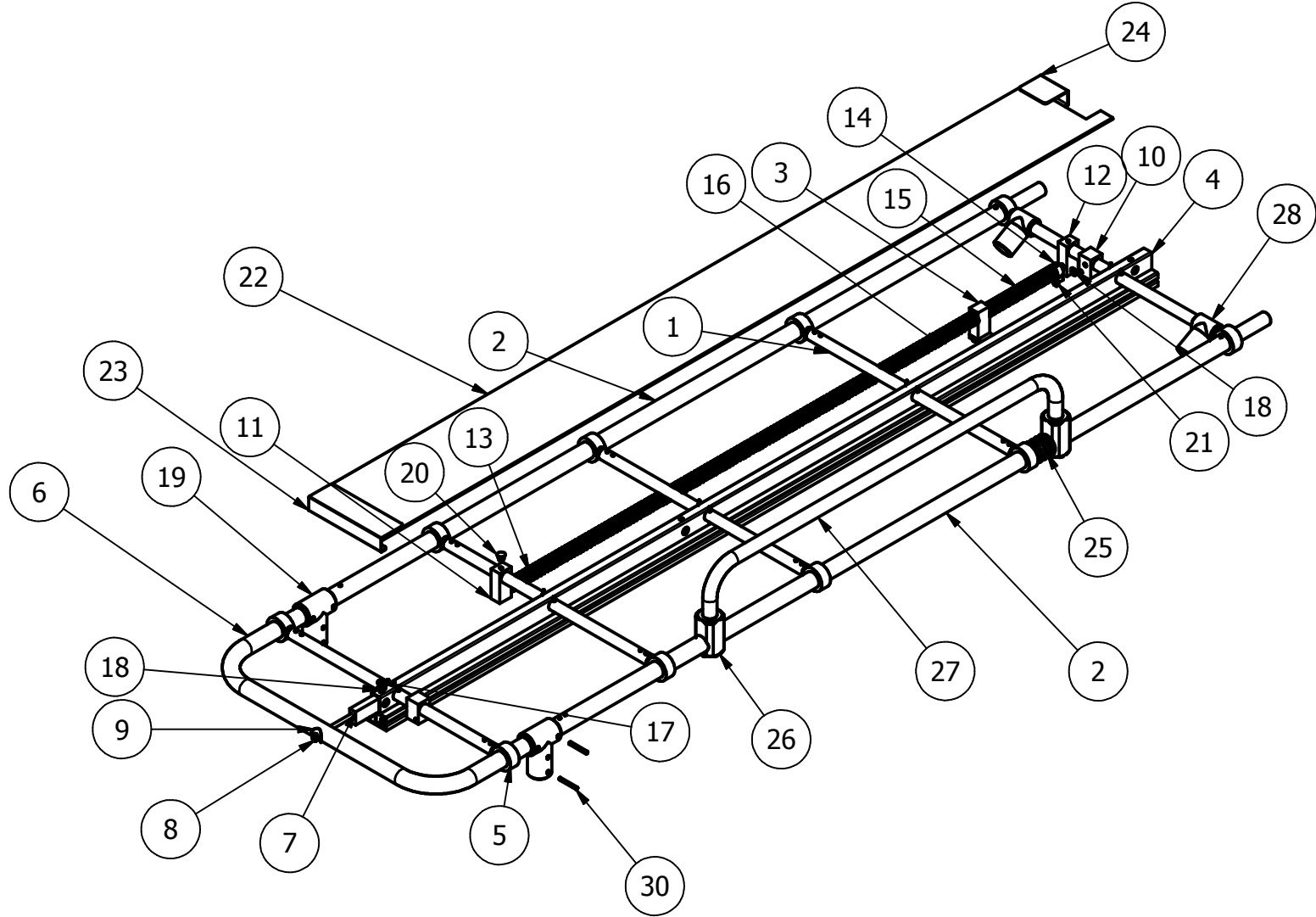

DRAWN BY:
DM

JUNKIN SAFETY APPL. CO.
3121 MILLERS LN
LOUISVILLE KY 40216

PT #

BED FRAME ASSY

(Pg 1)

DATE

9/29/08

MATERIAL

**NOTE-WHEN ORDERING PARTS "INDICATE" WIDEBODY,
SUBURBAN OR STANDARD SIZE COT**

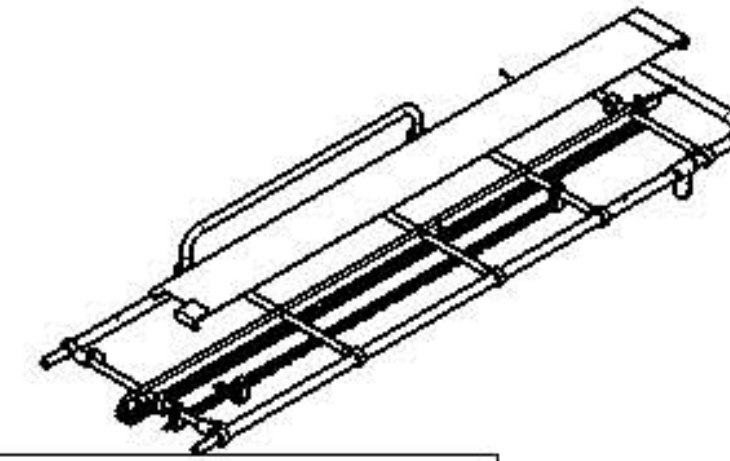

Parts List				Parts List			
ITEM	QTY	PART NUMBER	DESCRIPTION	ITEM	QTY	PART NUMBER	DESCRIPTION
1	5	MC-100-18A	CROSSBAR ASSY	16	1	MC-100-07	COMPRESSION SPRING-LONG
2	2	MC-100-52A	SIDERAIL ASSY	17	1	MC-100-128	1/4-20 x 7/8 Pan Hd Phillips
3	1	MC-100-109A	SPRING LOADER ASSY	18	2	1/4" Star Washer	1/4" External Washer
4	1	MC-100-01	CENTER EXTRUSION RAIL	19	2	MC-100-47	T-CASTING-POST
5	10	MC-100-03	CASTING-WITH TANG	20	1	MC-100-132	# 84 Pop Rivet Steel/Steel
6	1	MC-100-16	SWIVEL END TUBE	21	1	MC-100-133	1/4-20 x 1/2 Pan Hd Self Tapping Phillips Machine Screw
7	1	MC-100-117	MAIN RAIL TIE BAR	22	1	MC-100-43	Aluminum Decking
8	1	MC-100-143	1/4-20 x 3-1/4 Hex Hd Machine Screw	23	1	MC-100-51-Long	Panel End Cap-Long
9	1	MC-100-107	1/4" Foot Stop Wave Washer	24	1	MC-100-51-Short	Panel End Cap-Short
10	2	MC-100-25	HANGER STOP	25	1	MCSR-02	Pivot Block Spring
11	1	MC-100-29	RETURN SPRING SUPPORT-SWIVEL END	26	2	MCSR-01	PIVOT BLOCK
12	1	MC-100-29-A	RETURN SPRING SUPPORT-FOOT END	27	1	MCSR-03	SIDE ARM
13	1	MC-100-30	SPRING GUIDE ROD	28	2	MC-100-04	Rigid Leg T-Casting
14	1	MC-100-89	.437 STOP COLLAR	30	2	MC-100-135	3/16 X 1-1/2 ROLL PIN
15	1	MC-100-10	COMPRESSION SPRING-SHORT				

DRAWN BY:

DM

JUNKIN SAFETY APPL. CO.
3121 MILLERS LN
LOUISVILLE KY 40216

PT #

BED FRAME ASSY

(Pg 2)

DATE

9/29/08

MATERIAL

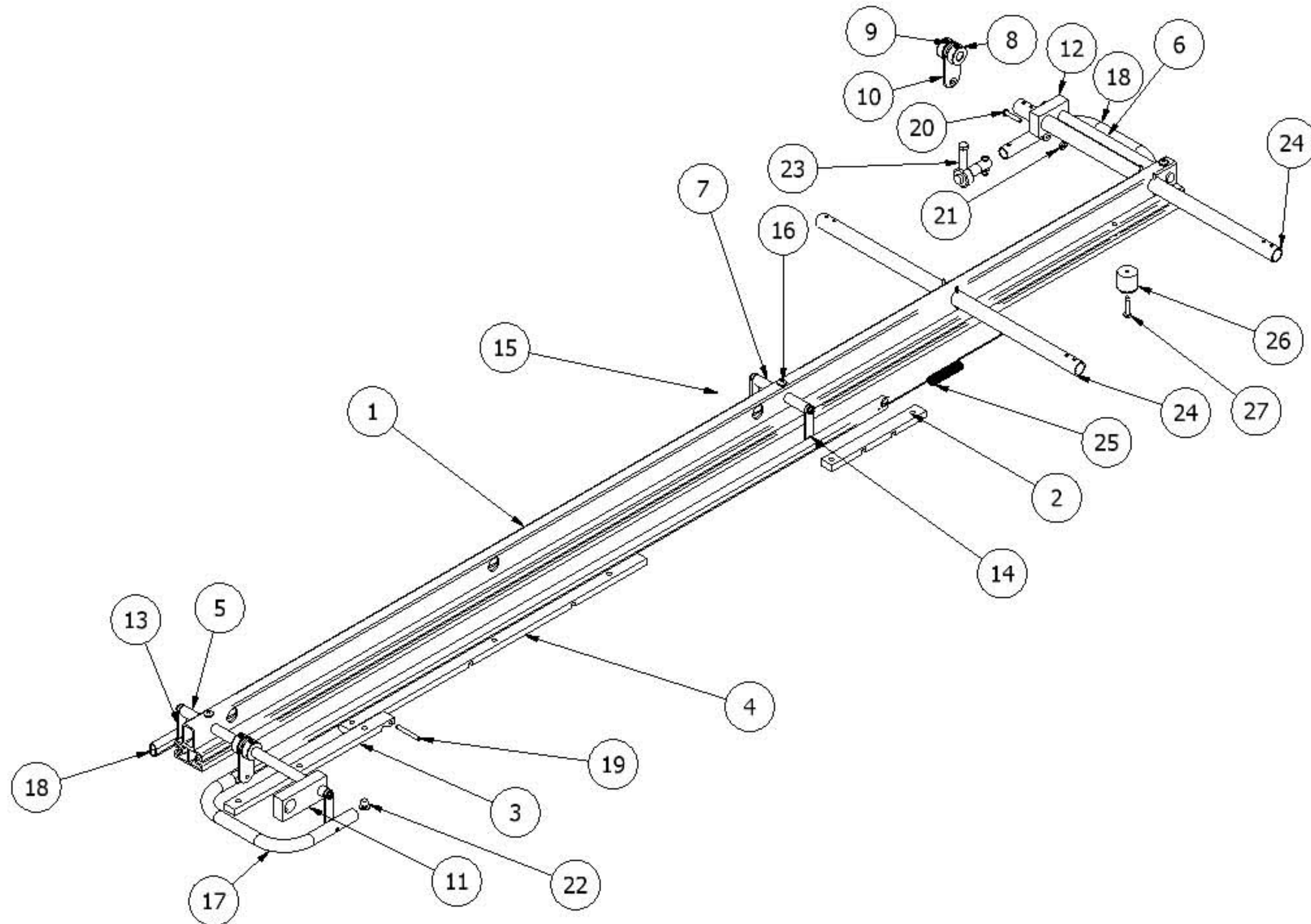

DRAWN BY: DM	JUNKIN SAFETY APPL. CO. 3121 MILLERS LN LOUISVILLE KY 40216	PT #	EXTRUSION ASSY	(Pg 1)
		DATE 9/25/08	MATERIAL	

NOTE-WHEN ORDERING PARTS "INDICATE" SUBURBAN,WIDEBODY OR STANDARD SIZE COT

Parts List				Parts List			
ITEM	QTY	PART NUMB	DESCRIPTION	ITEM	QTY	PART NUMB	DESCRIPTION
1	1	MC-100-01	EXTRUSION1	15	5	MC-100-84	10-24 Shoulder Bolt
2	1	MC-100-23	LOCKING STRIP-SHORT	16	3	MC-100-118	1/4-20 x 3/4 Phillips Hd Machine Screw
3	1	MC-100-22	LOCKING STRIP-MEDIUM				
4	1	MC-100-21	LOCKING STRIP-LONG	17	1	MC-100-39	CONTROL HANDLE-SHORT
5	1	MC-100-26	HANGER ROD-9-3/4	18	1	MC-100-38	CONTROL HANDLE-LONG
6	1	MC-100-27	HANGER ROD-8-1/4	19	1	MC-100-135	3/16 x 1-1/2 Roll Pin
7	1	MC-100-28	HANGER ROD-3-1/2	20	1	MC-100-130	10-24 x 1 Socket Button Hd Machine Screw
8	4	MC-100-112	1/2" Shaft Collar				
9	4	MC-100-82	NYLON WASHER-1/2 IN	21	1	MC-100-131	10-24 Nylon Lock Nut
10	2	MC-100-15	HANGER-1 INCH	22	1	MC-100-132	# 84 Steel/Steel Pop Rivet
11	1	MC-100-48	HANGER ROD SUPPORT-LONG	23	1	MC-100-95A	CONTROL HANDLE STOP ASSY
12	1	MC-100-49	HANGER ROD SUPPORT-SHORT				
13	5	MC-100-24	HANGER NARROW	24	2	MC-100-18A	CROSSBAR ASSY
14	7	MC-100-70	NYLON WASHER-3/16	25	2	MC-100-46	CONTROL HANDLE RETURN SPRING
				26	1	MC-100-69	Rubber Bumper
				27	1	MC-100-137	10-24 X 1" Pan HD Type F Screw

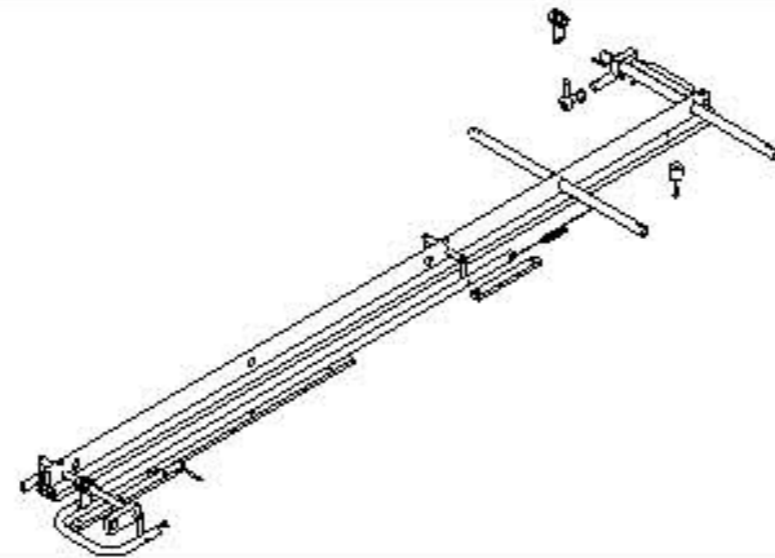

DRAWN BY:

DM

JUNKIN SAFETY APPL. CO.
3121 MILLERS LN
LOUISVILLE KY 40216

PT #

EXTRUSION ASSY

(Pg 2)

DATE 9/25/08

MATERIAL

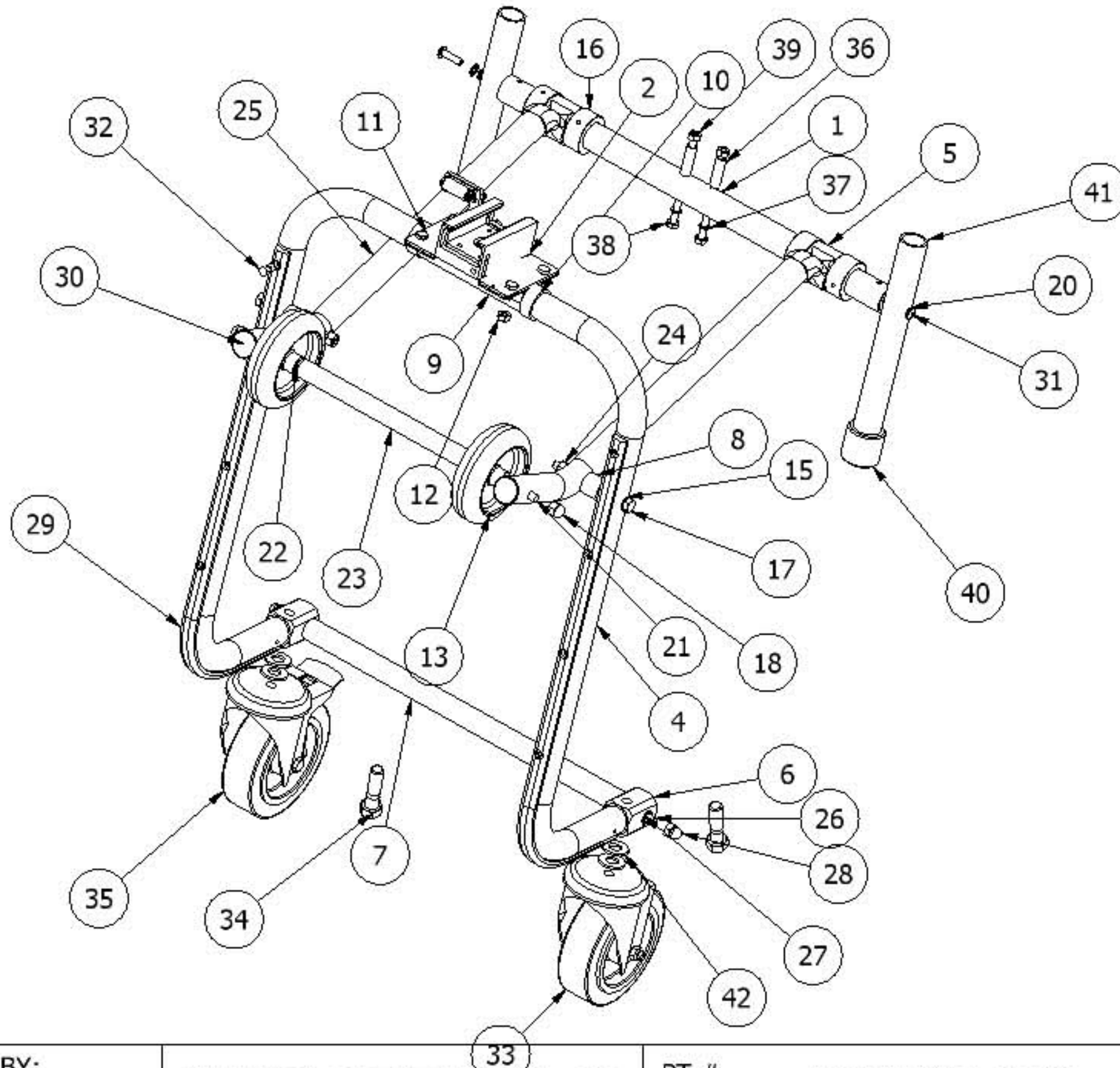

DRAWN BY:	JUNKIN SAFETY APPL. CO. 3121 MILLERS LN LOUISVILLE KY 40216	PT #	LEG-SWIVEL ASSY	(pg 1)
DM		DATE 9/19/08	MATERIAL	

Parts List				Parts List			
ITEM	QTY	PART NUMBER	DESCRIPTION	ITEM	QTY	PART NUMBER	DESCRIPTION
1	1	MC-100-96A	LOWER CROSSBAR ASSY	23	1	MC-100-98	LOADER WHEEL CROSSTUBE-4 IN
2	1	SLIDE ASSY					
4	1	MC-100-19A *	LEG-SWIVEL-SEE BELOW	24	2	MC-100-104	5/16-18 Nylon Locking Hex Nut
5	2	JSA-604-13	LARGE OFFSET CASTING				
6	2	MC-100-06	WHEEL BASE	25	2	MC-100-20	LEG SUPPORT-SWIVEL END
7	1	MC-100-54	LOWER CROSSBAR-SWIVEL END	26	1	MC-100-114	ALL-THREAD LOWER CROSSBAR-SWIVEL END
8	2	MC-100-58	SPACER-NYLON	27	2	Star Washer	5/16 Star Washer
9	1	MC-100-05	U-PLATE	28	2	MC-100-68	5/16-18 Acorn Nut
10	2	MC-100-37	RING	29	2	MC-100-11B	BUMPER STRIP -LONG
11	4	MC-100-119	1/4-20 X 1/2 Hex Cap Screw	30	2	MC-100-83	CAP PLUG
12	4	MC-100-103	Nylon Locking Hex Nut	31	2	MC-100-118	1/4-20 X 7/8 Phillips Pan Hd Machine Screw
13	2	MC-100-80	LOADER WHEEL-4 INCH				
14	2	MC-100-81	LOAER WHEEL BUSHING 4 IN	32	10	MC-100-126	#66 Alum/Steel Pop Rivet
				33	1	MC-100-40	5" Swivel Wheel
15	10	MC-100-100	.312 Flat Washer	34	2	MC-100-127	1/2-13 X 2 INCH
16	4	JSA-602-5	Collar Casting	35	1	MC-100-41	5" Swivel Locking Wheel
17	2	MC-100-113	5/16 X 3-1/2 Hex Hd Machine Screw	36	2	MC-100-91	LOWER CROSSBAR STANDOFF-SWIVEL END
18	3	MC-100-68	5/16-18 Acorn Nut	37	2	MC-100-129	.250 WASHER
20	2	STAR WASHER	1/4 Inch Star Washer	38	2	MC-100-102	1/4-20 x 3-3/4 Hex Hd Machine Screw
21	1	MC-100-97	ALL-THREAD 4 IN LOADER WHEEL	39	2	MC-100-103	1/4 Nylon Lock Nut
22	2	MC-100-36	BUSHING	40	2	MC-100-45A	LEG POST ASSY
				40	2	MC-100-63	LEG POST TIP-NYLON
				41	2	MC-100-45A	LEG POST ASSY
				42	4	MC-100-139	1/2" FLAT SAE WASHER

**NOTE-WHEN ORDERING PARTS "INDICATE" OVERSIZE,
SUBURBAN OR REGULAR SIZE COT**

*** LEG SWIVEL ASSY INCLUDES- MC-100-19 SWIVEL LEG , MC-100-06 WHEEL BASE
MC-100-54 LOWER CROSSBAR, MC-100-11 BUMPER STRIPS**

DRAWN BY: DM	JUNKIN SAFETY APPL. CO. 3121 MILLERS LN LOUISVILLE KY 40216	PT #	LEG-SWIVEL ASSY	(pg 2)
		DATE 9/19/08	MATERIAL	

3. Remove the slide item # 1 from the main rail by pulling it down the main rail all the way till it is disconnected from the cot.

NOTE-WHEN ORDERING PARTS "INDICATE" WIDEBODY, SUBURBAN OR STANDARD SIZE COT

Parts List			
ITEM	QTY	PART NUMBER	DESCRIPTION
1	1	MC-100-02A-LOAD END *	Slide Assy-Loading End
2	2	MC-100-42 (002309)	WHEEL- 5 INCH RUBBER
3	1	MC-100-31A **	RIGID LEG ASSY - SEE BELOW
4	2	MC-100-08	RIGID WHEEL CASTING
6	2	MC-100-37	RING
8	8	MC-100-100	5/16 X .316 X .062 Flat Washer
9	2	JSA-604-13	LARGE OFFSET CASTING
10	1	MC-100-55	LOWER CROSSBAR TUBE-RIGID END
11	2	MC-100-125	5/16-18 X 3 Hex Hd Machine Screw
12	4	MC-100-104	Hex Nut -Nylon Locking
13	2	MC-100-88	5/16-18 X 2-3/4 Hex Hd Machine Screw
14	2	MC-100-11A	BUMPER STRIP-SHORT
15	8	MC-100-126	#64 Alum/Steel Pop Rivet
16	2	MC-100-32	LEG SUPPORT-RIGID END
17	1	MC-100-105A	LEG SUPPORT CROSSBAR ASSY

**** MC-100-31A INCLUDES - MC-100-31 LEG
MC-100-08 WHEEL HOUSINGS(Wheels not included)
MC0100-11A BUMPER STRIPS**

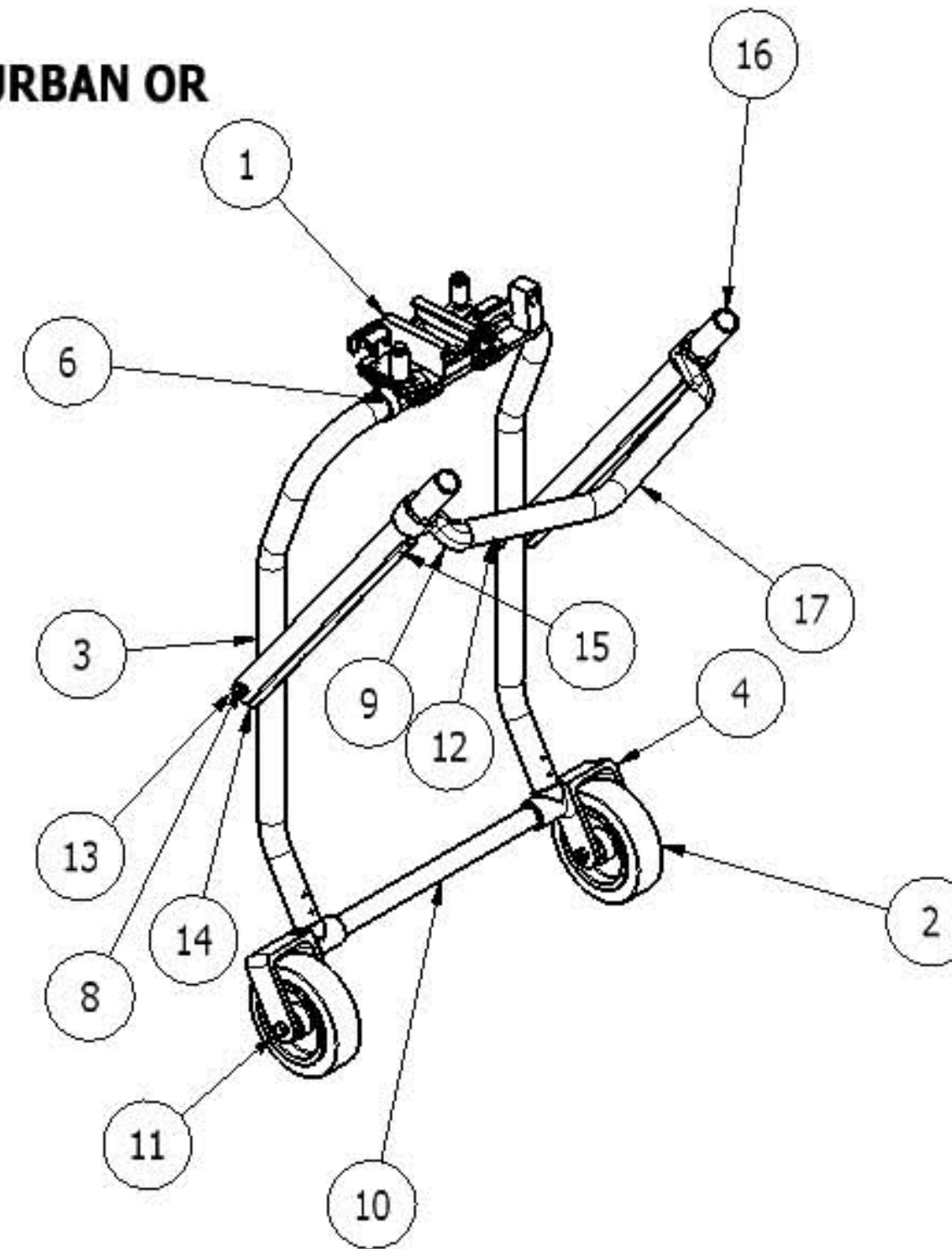

***MC-100-02A INCLUDES-MC-100-02 SLIDE
MC-100-12 BASEPLATE
MC-100-09A LEVER ASSY(2/EA)
MC-100-75 SLIDE PIN
MC-100-110 BASEPLATE HEX NUT**

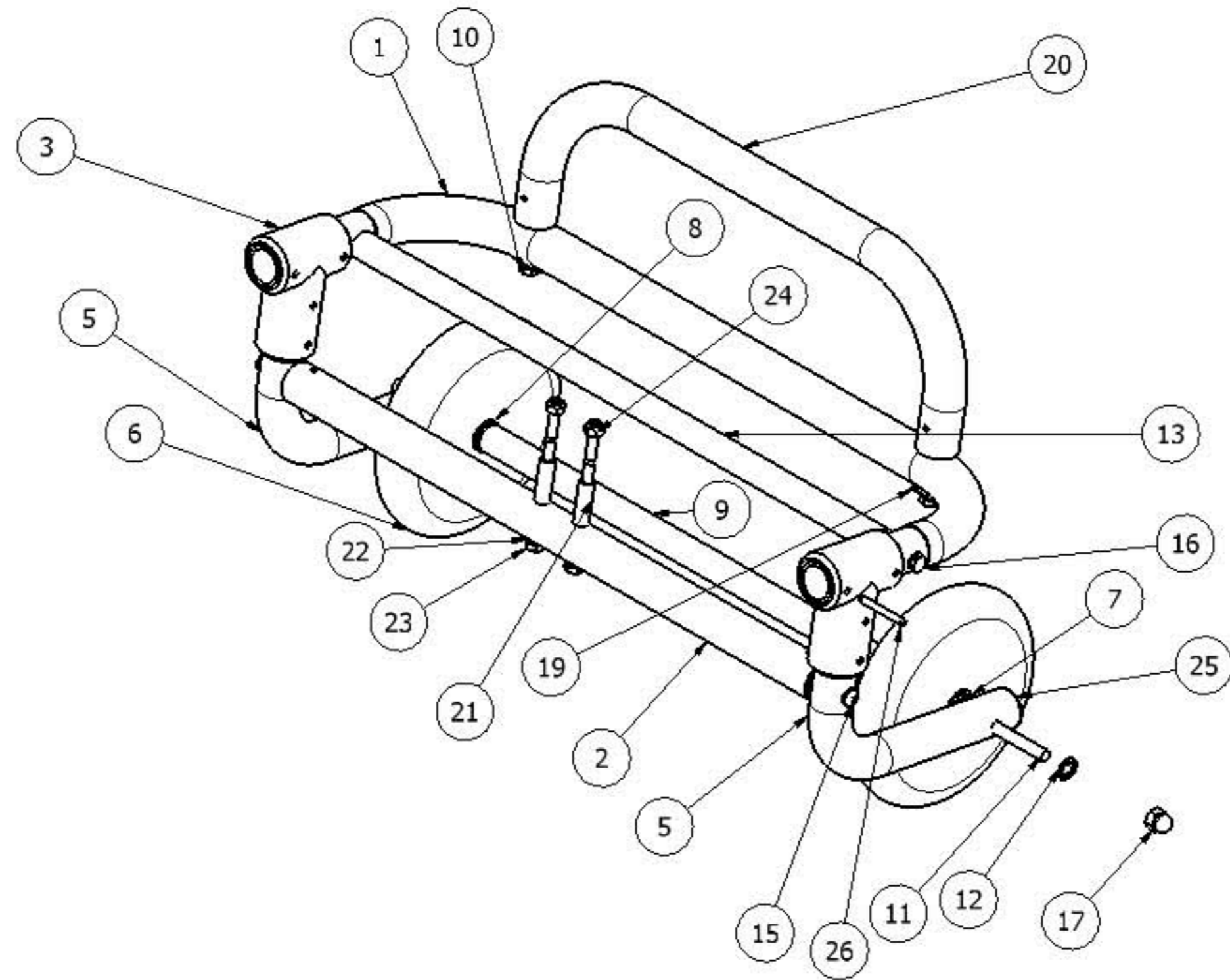

DRAWN BY:

JUNKIN SAFETY APPL. CO.
3121 MILLERS LN
LOUISVILLE KY 40216

PT #

LOADER END WHEEL ASSY

(Pg 1)

DATE

7/8/2010

MATERIAL

NOTE-WHEN ORDERING PARTS"INDICATE" WIDEBODY,SUBURBAN OR STANDARD SIZE COT



Parts List				Parts List			
ITEM	QTY	PART NUMBER	DESCRIPTION	ITEM	QTY	PART NUMBER	DESCRIPTION
1	1	MC-100-59(A) *	RIGID END TUBE	15	2	MC-100-118	ALUMINUM REDUCER SCREW
2	1	MC-100-96A	LOWER CROSSBAR ASSY	16	2	MC-100-116	1/4-20 X 1-3/4 HEX HD CAP SCREW
3	2	MC-100-47	T-POST CASTING	17	2	MC-100-68	ACRON NUT 5/16-18
5	1	MC-100-53	WHEEL POST-SET(Left/Right)	19	2	MC-100-107	1/4 INCH WAVE WASHER
6	2	MC-100-78	6 INCH LOADER WHEEL	20	1	MC-100-44A	FOOT STOP ASSY
7	4	MC-100-100	5/16 X .062 FLAT WASHER	21	2	MC-100-92	LOWER CROSSBAR STANDOFF-RIGID END
8	2	MC-100-36	BUSHING	22	2	MC-100-129	1/4" X .062 Thick Washer
9	1	MC-100-101	LOADER WHEEL CROSS TUBE	23	2	MC-100-102	1/4-20 X 3-3/4 Hex Hd Cap Screw
10	2	MC-100-141	1/4-20 X 1 HEX Hd Machine Screw	24	2	MC-100-103	1/4-20 NYLON LOCK NUT
11	1	MC-100-57	ALL-THREAD-6 IN LOADER WHEEL	25	1	MC-100-83	CAP PLUG
12	2	5/16 STAR WASHER	5/16 INTERNAL TOOTH	26	8	MC-100-135	3/16 X 1-1/2 ROLL PIN
13	1	MC-100-99	CROSSBAR-END				

*** NOTE: PT# MC-100-59A IS THE ENTIRE ASSEMBLY**

DRAWN BY:	JUNKIN SAFETY APPL. CO. 3121 MILLERS LN LOUISVILLE KY 40216	PT #	LOADER END WHEEL ASSY (Pg 2)
DM		DATE	MATERIAL
		7/8/2010	

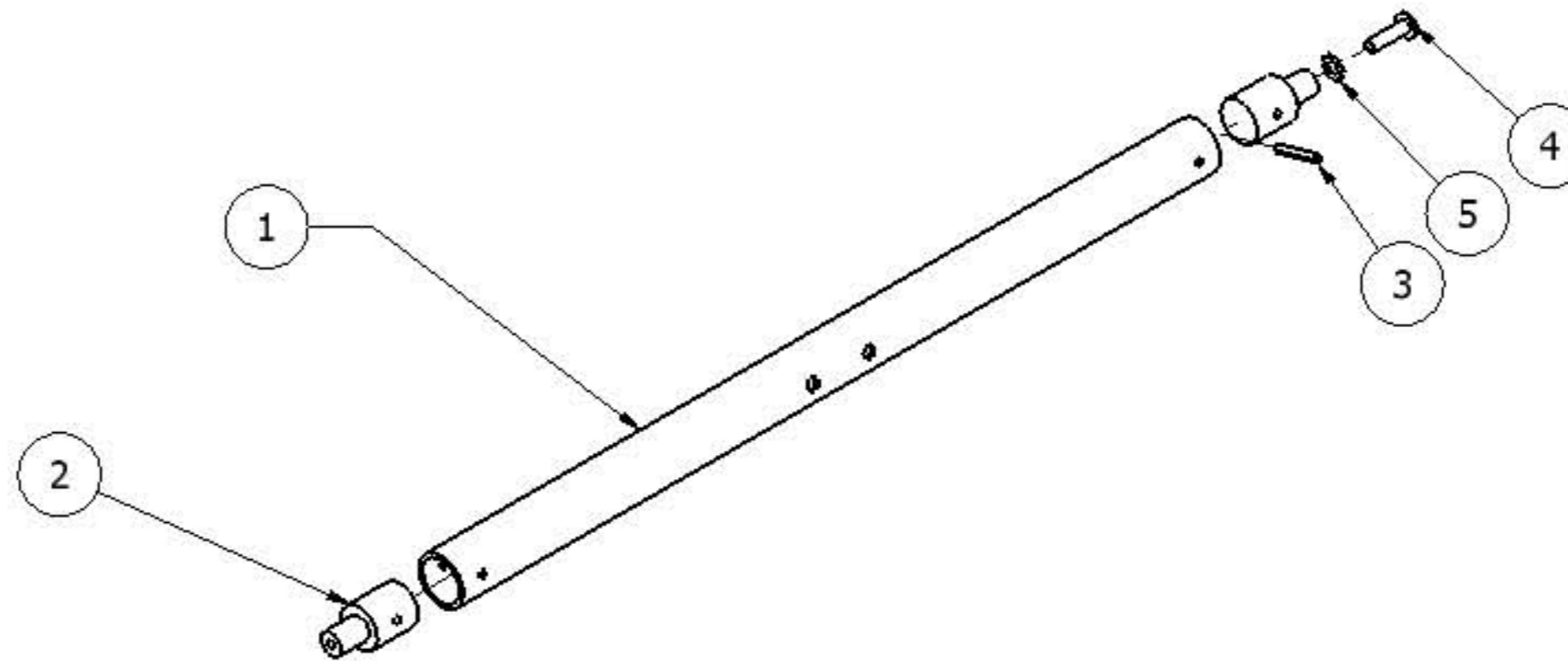

NOTE-WHEN ORDERING PARTS "INDICATE" WIDEBODY,SUBURBAN OR STANDARD SIZE COT

Parts List			
ITEM	QTY	PART NUMBER	DESCRIPTION
1	1	MC-100-96A *	LOWER CROSSBAR
2	2	MC-100-33-500	REDUCER-ALUMINUM-.500
3	2	MC-100-138	Pin - Slotted Spring
4	2	MC-100-118	1/4-20 X 7/8 PHILLIPS D
5	2	1/4 INCH STAR WASHER	External Tooth Washer

*NOTE: PT# MC-100-96A INCLUDES ITEMS # 1,2,& 3

DRAWN BY:

DM

JUNKIN SAFETY APPL. CO.
3121 MILLERS LN
LOUISVILLE KY 40216

PT #

MC-100-96A LOWER CROSSBAR ASSY

DATE
57/23/2007

MATERIAL

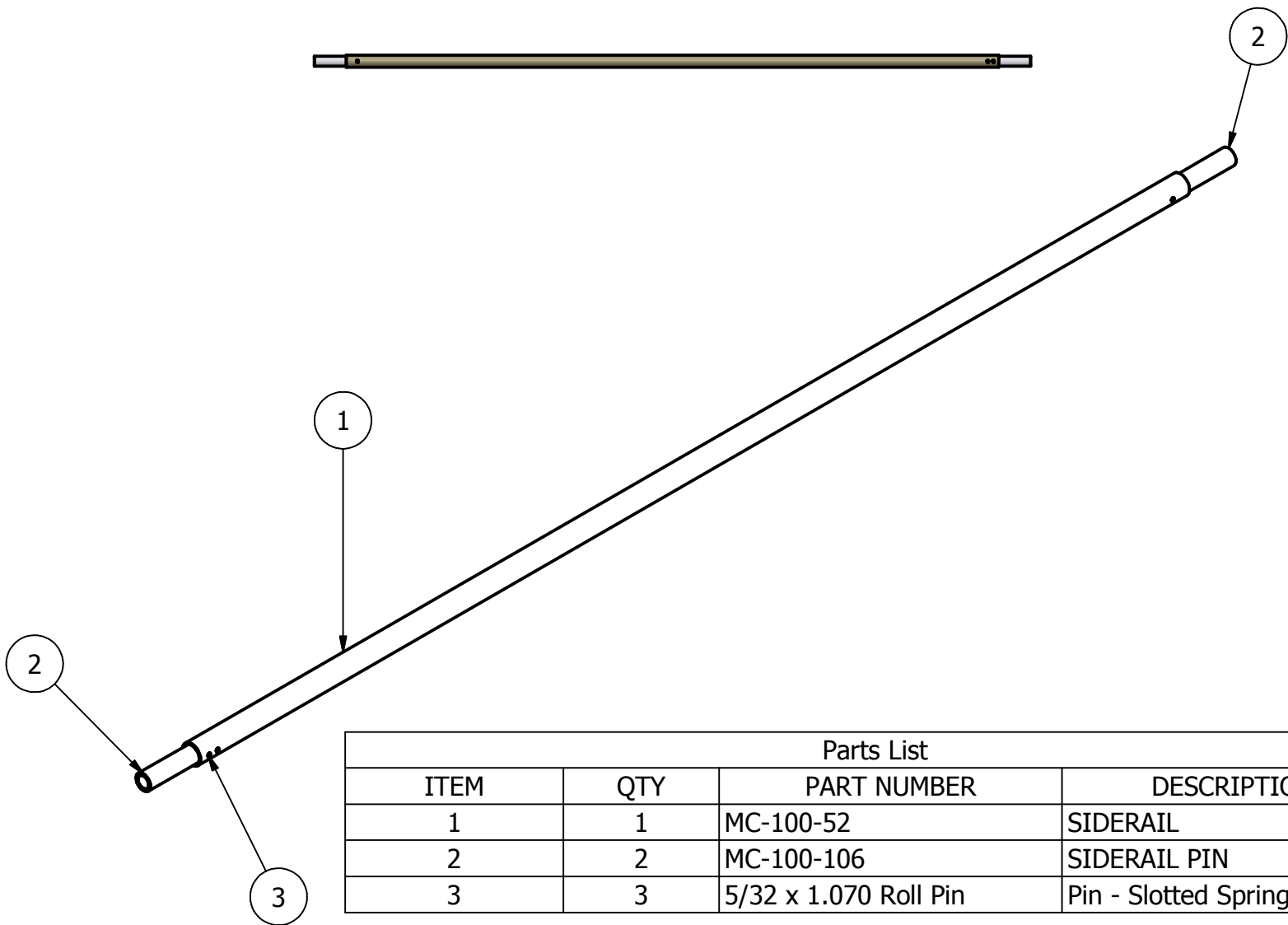

Parts List			
ITEM	QTY	PART NUMBER	DESCRIPTION
1	1	MC-100-52	SIDERAIL
2	2	MC-100-106	SIDERAIL PIN
3	3	5/32 x 1.070 Roll Pin	Pin - Slotted Spring

DRAWN BY: DM	JUNKIN SAFETY APPL. CO. 3121 MILLERS LN LOUISVILLE KY 40216	PT # SIDERAIL ASSY	
		DATE 10/08/08	MATERIAL

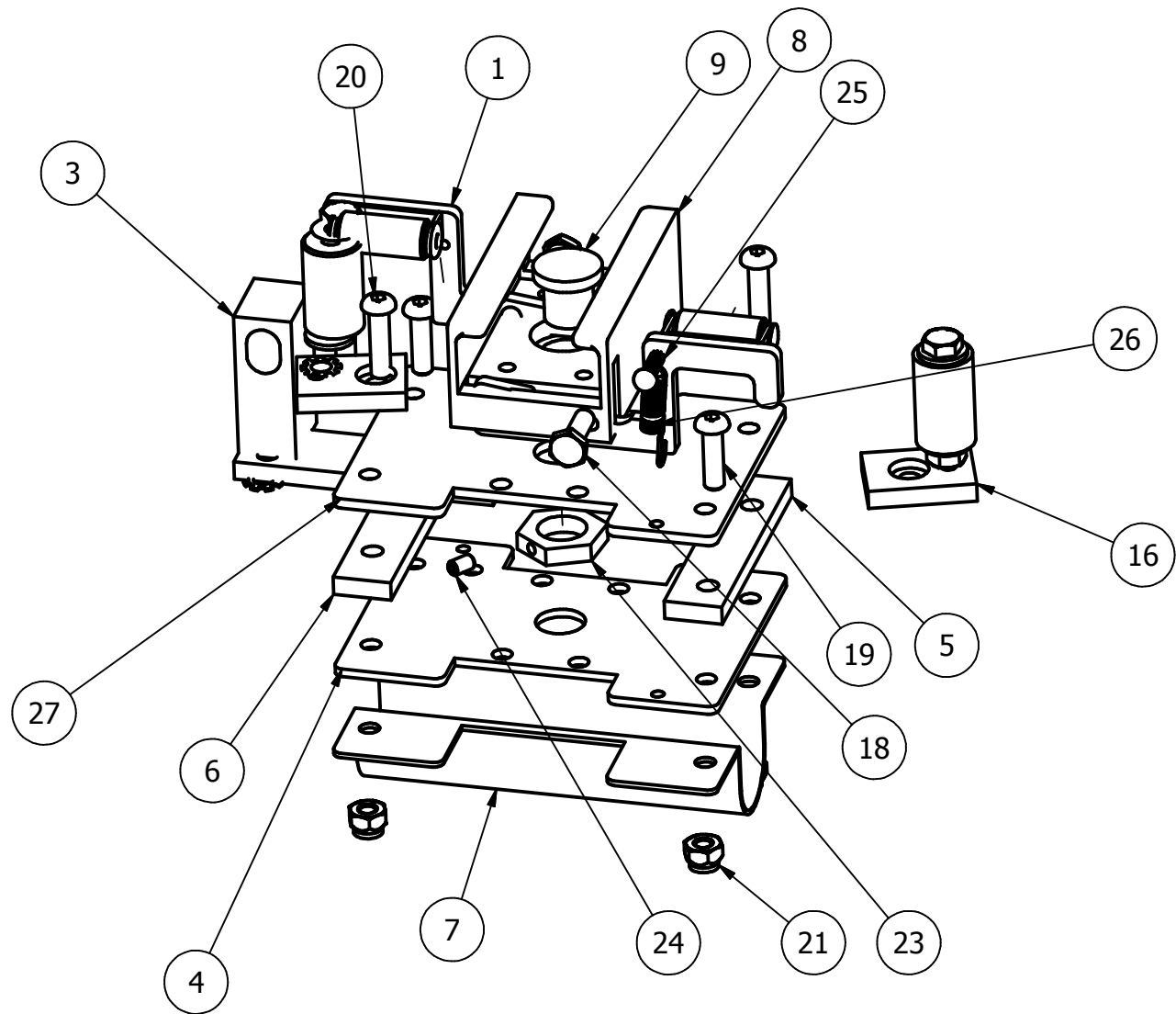

DRAWN BY:

JUNKIN SAFETY APPL. CO.
3121 MILLERS LN
LOUISVILLE KY 40216

PT #

SLIDE ASSY-LOAD END

(pg 1)

DATE

9/18/08

MATERIAL

Parts List				Parts List			
ITE	QTY	PART NUMBER	DESCRIPTION	ITE	QTY	PART NUMBER	DESCRIPTION
1	2	MC-100-09A	LEVER ASSY	16	1	MC-100-60A	Control Handle Guide Assy
3	1	MC-100-109A	SPRING LOADER PLATE ASSY	18	2	MC-100-121	1/4-20 X 5/8 Socket Hd Machine Screw
4	1	MC-100-12	BASEPLATE	19	3	MC-100-122	1/4-20 X 7/8 Socket Hd Machine Screw
5	1	MC-100-76	BASEPLATE STANDOFF-LONG	20	2	MC-100-123	1/4-20 X 1" Socket Hd Machine Screw
6	1	MC-100-77	BASEPLATE STANDOFF-SHORT	21	5	MC-100-103	1/4-20 Nylon Lock Nut
7	1	MC-100-05	U-PLATE	23	1	MC-100-110	Baseplate Hex Nut
8	1	MC-100-02* (A-L)	SLIDE	24	1	MC-100-124	10-24 x 1/4 Socket Set Screw
9	1	MC-100-75	SLIDE PIN	25	1	MC-100-79	Drive Screw
11	1	MC-100-67	NYLON GUIDE ROLLER	27	1	MC-100-12-10GA	BASEPLATE

***NOTE: MC-100-02A-L IS THE SLIDE ASSEMBLY COMPLETE**

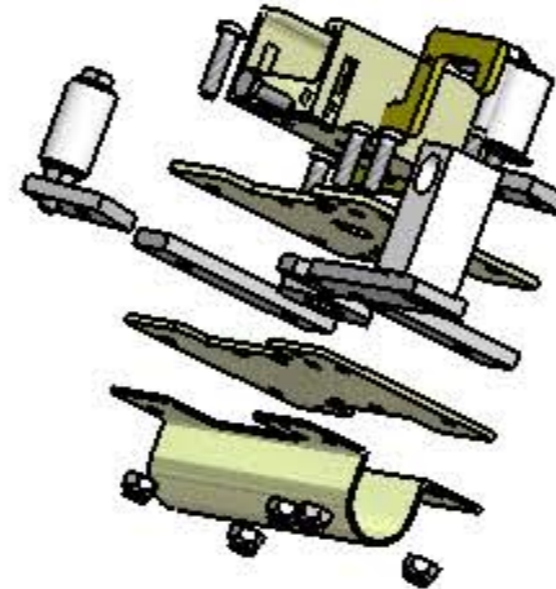

DRAWN BY:	JUNKIN SAFETY APPL. CO. 3121 MILLERS LN LOUISVILLE KY 40216	PT #	SLIDE ASSY-LOAD END	(pg 2)
		DATE 9/18/08	MATERIAL	

SLIDE ASSY-NON LOADING END

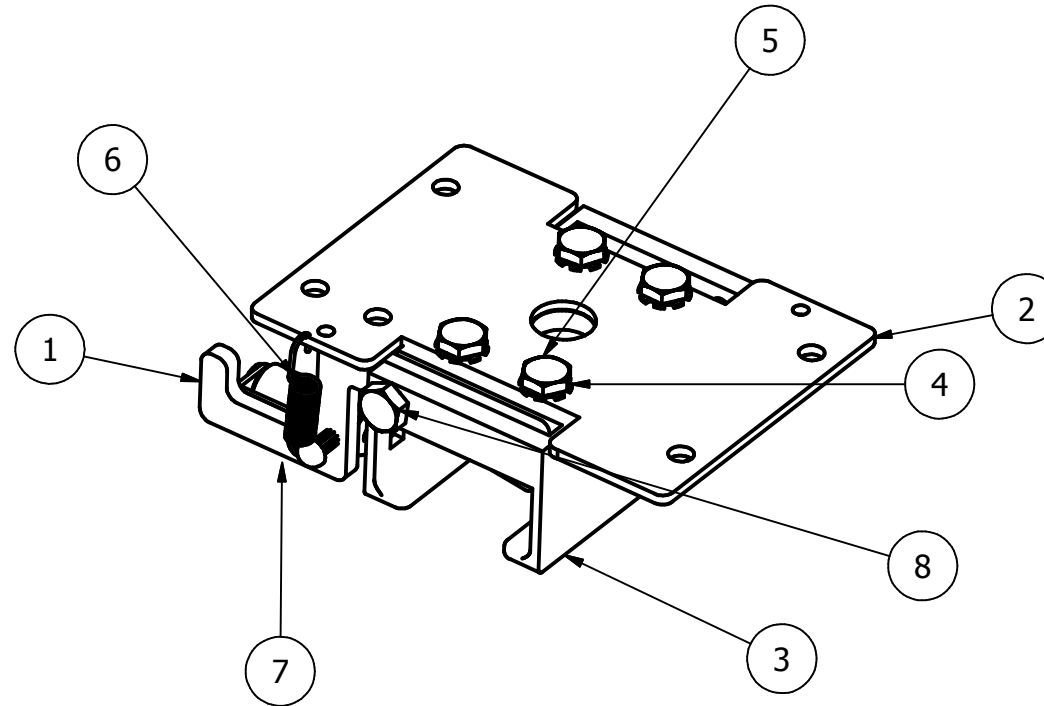

Parts List

ITEM	QTY	PART NUMBER	DESCRIPTION
1	1	MC-100-09A	LEVER ASSY
2	1	MC-100-12	BASEPLATE
3	1	MC-100-02	SLIDE1
4	4	MC-100-120	1/4" Split Lock Washer
5	4	MC-100-119	Base Plate Bolts 1/4-20 X 1/2 Long
6	1	MC-100-13	SPRING-LEVER
7	1	MC-100-79	#8 X 5/8 Drive Screw
8	1	MC-100-121	Lever Screw Hex Hd. 1/4-20 X 5/8 Long

5/20/05

JUNKIN SAFETY APPL. CO.
3121 MILLERS LN
LOUISVILLE KY 40216

1

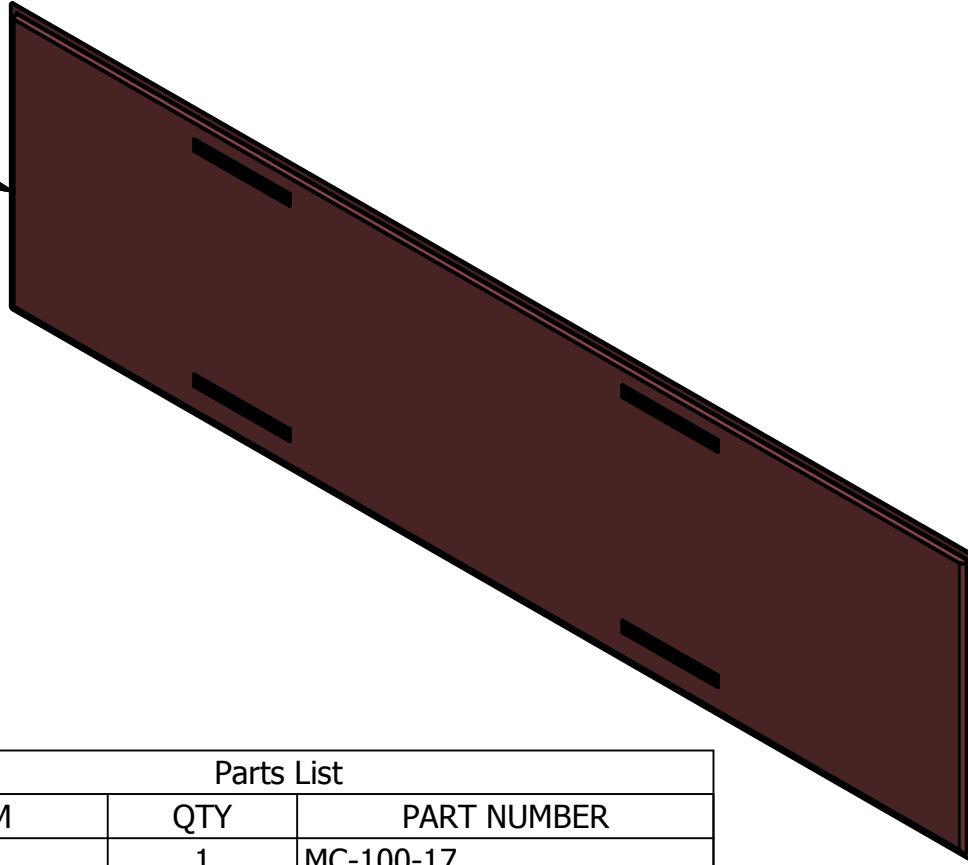

Parts List		
ITEM	QTY	PART NUMBER
1	1	MC-100-17

FOR WIDEBODY COT ORDER PT# MC-100-17WB

DRAWN BY:	JUNKIN SAFETY APPL. CO. 3121 MILLERS LN LOUISVILLE KY 40216	PT #	MC-100-17 COT PAD
		DATE	MATERIAL

2/9/2010

The stop collar adjustment is located in this area.

Lubricate the rod below in the area where the arrow is.

These are the adjust screws for the control handle.

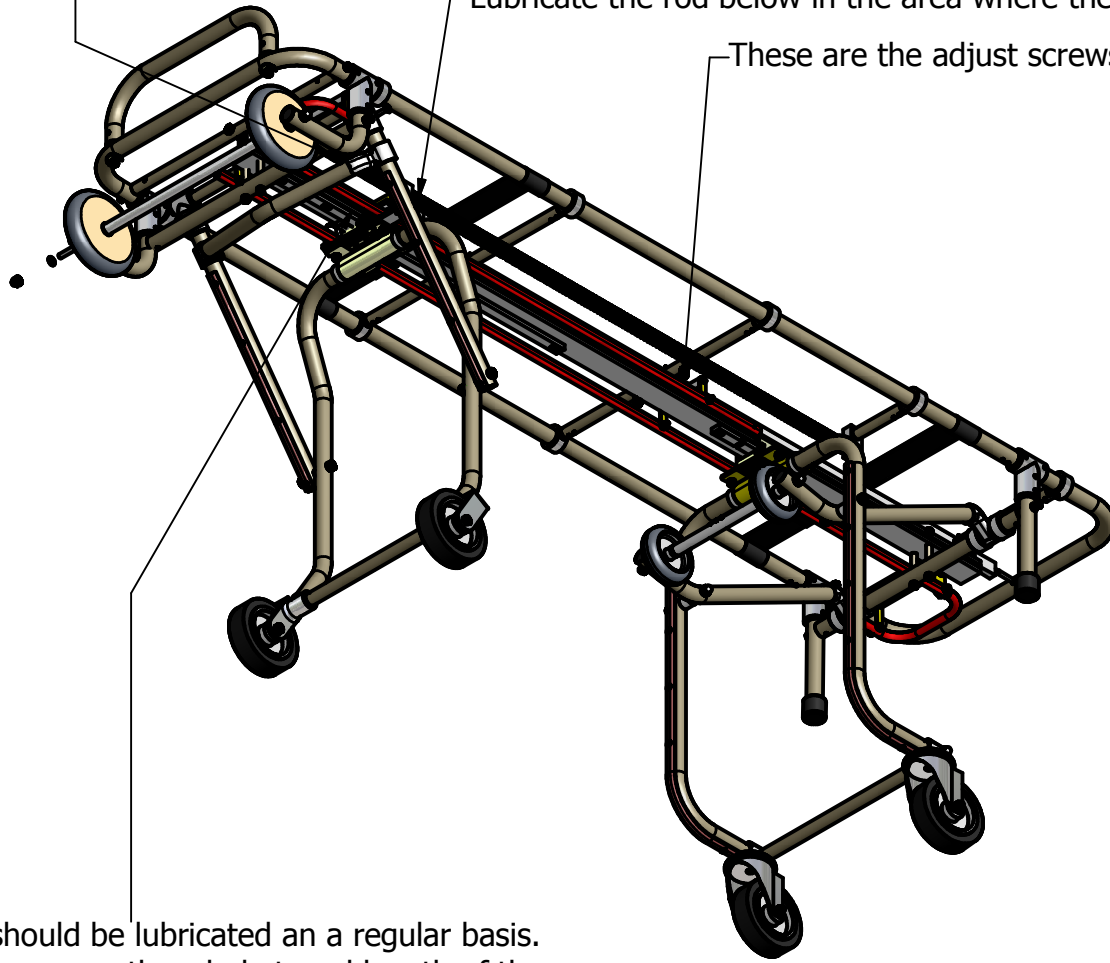

This is the slide that should be lubricated on a regular basis. Apply grease in the groove on the whole travel length of the slide.

DRAWN BY:

JUNKIN SAFETY APPL. CO. 3121 MILLERS LN LOUISVILLE KY 40216	PT #	SERVICE TIPS	
	DATE	MATERIAL	

UNLOADING COT DIRECTIONS TO AVOID A "DROP"

1. WHEN UNLOADING THE COT, AS THE SECOND SET OF LEGS COMES OUT OF THE VEHICLE AND SWINGS DOWN AND LOCKS INTO POSITION FOLLOW THE DIAGRAM BELOW TO MAKE SURE THE LEGS ARE LOCKED INTO THE HOME POSITION BEFORE ROLLING THE COT AWAY FROM VEHICLE.

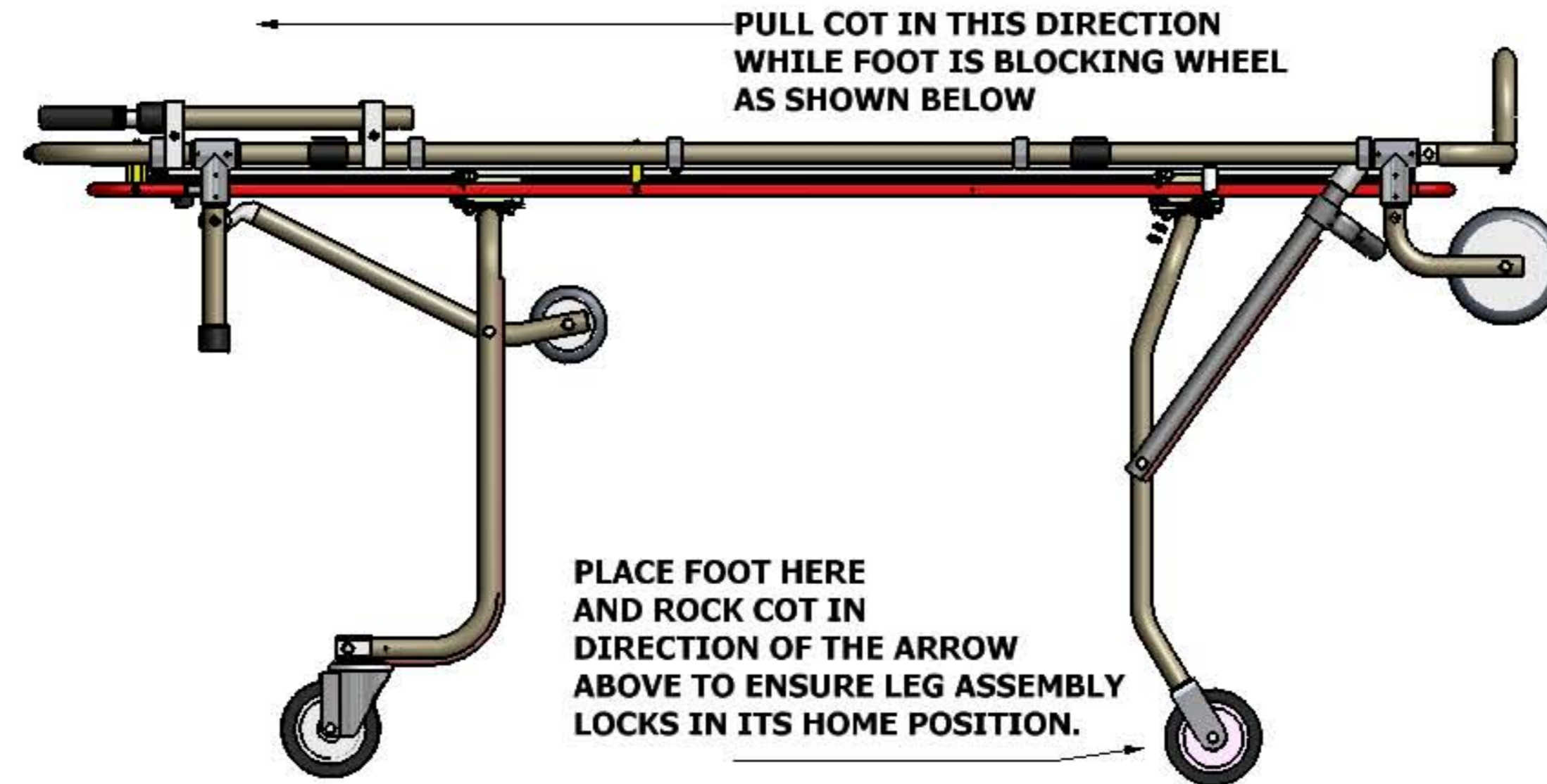

JUNKIN SAFETY APPL. CO.
3121 MILLERS LN
LOUISVILLE KY 40216

OPERATING INSTRUCTIONS: LIFT THIS END FIRST!!!!

When a single operator is raising the cot, he/she must raise the non-loading end first. This is the end with the posts.

After it has been raised to its desired height, the operator can then lift the Loading end.

If this procedure is not followed, it could result in a drop.

W.Chris Mercke
President

MC-100 SPRING ADJUSTMENT INSTRUCTIONS

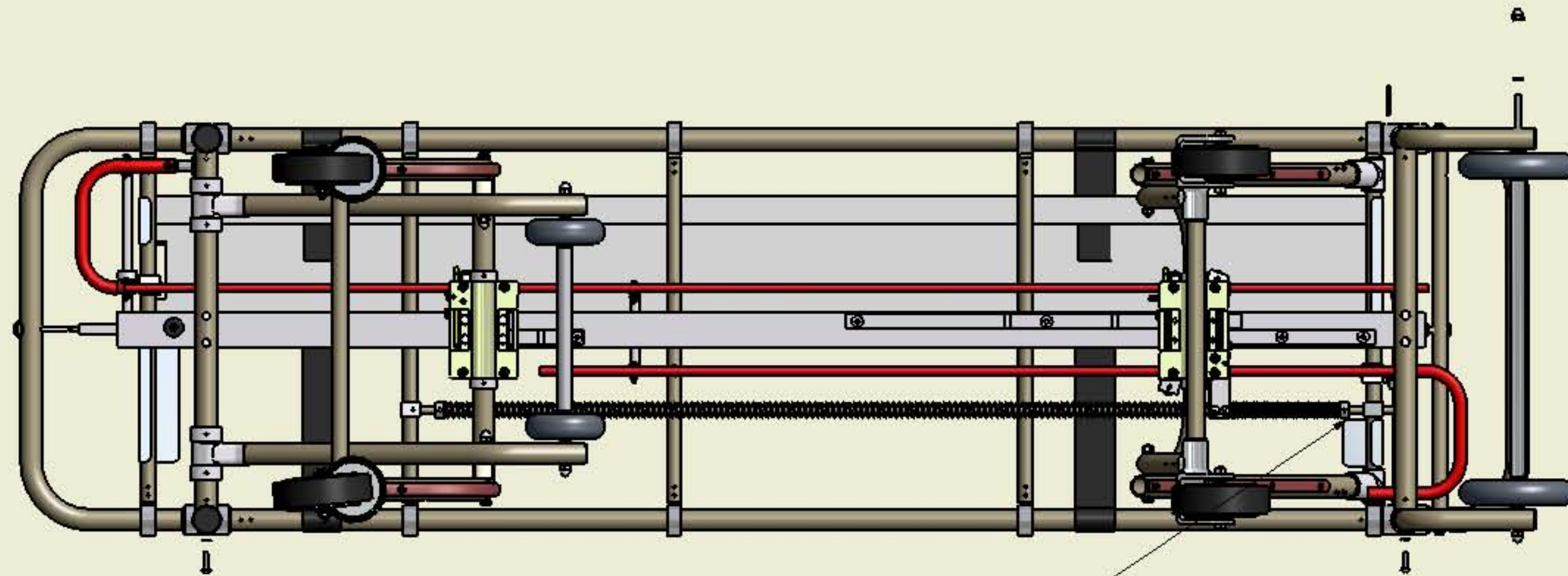

Adjust the shaft collar for desired results. Compressing the spring make it harder to load the cot (fold the legs), but at the same time when unloading the cot the legs "snap" into position much easier. If the cot is difficult to load then you would want to move the shaft collar to the right to soften the tension on the spring.

These changes sometimes need to be made depending on the configuration of your vehicle.

DRAWN BY:

JUNKIN SAFETY APPL. CO.
3121 MILLERS LN
LOUISVILLE KY 40216

PT #

DATE

MATERIAL

IMPORTANT NOTICE

All pivot points and moving parts are to be lubricated on a regular basis. Failure to do so will result in poor performance of the cot. It is suggested that a light to medium weight oil be used on all pivot points and a Teflon grease be used on the slide mechanism.

NOTE-The best way to lubricate all points of the cot is to lay the cot upside-down on a table so you can see the slides, control handle hangers, etc.

Points of Lubrication

1. The red control handle hangers. These are the parts that connect the red control handle to the main frame of the cot,. There are 6 points one on one control handle and 8 points on the other handle.
2. The pivot points on the legs where the leg supports connects to the leg themselves.
3. The slide mechanism.-This is the most important part to keep lubricated. Using a “Teflon” grease , apply a coat of grease to anywhere on the main rail that the slide comes in contact with. This is recommended to be performed after every washing or as per needed.

CONTROL HANDLE ADJUSTMENT PROCEDURE

- 1** In order to maintain proper operation of your cot it may become necessary to make adjustments periodically. The clearance between the control lever and the white nylon roller on the slide lever should be at a maximum of 1/16"

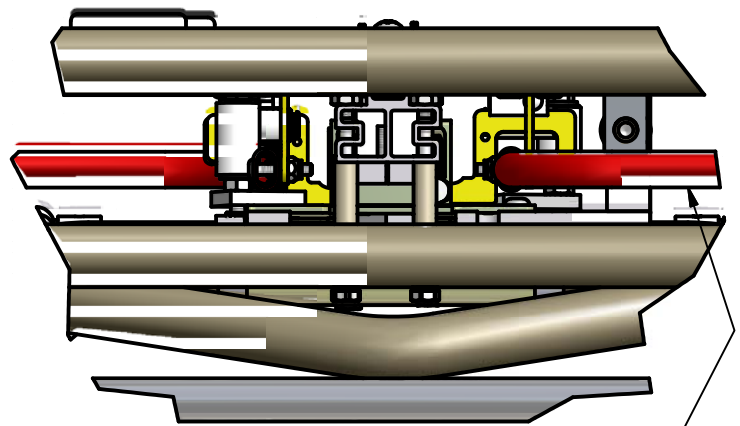

CONTROL HANDLE

2

Turn the 1/4-20 stop screw in or out for desired result

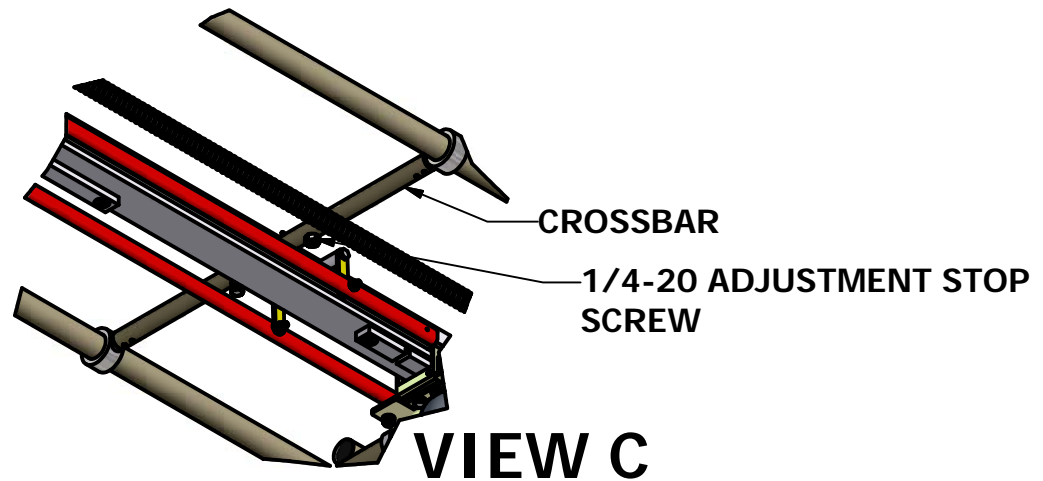
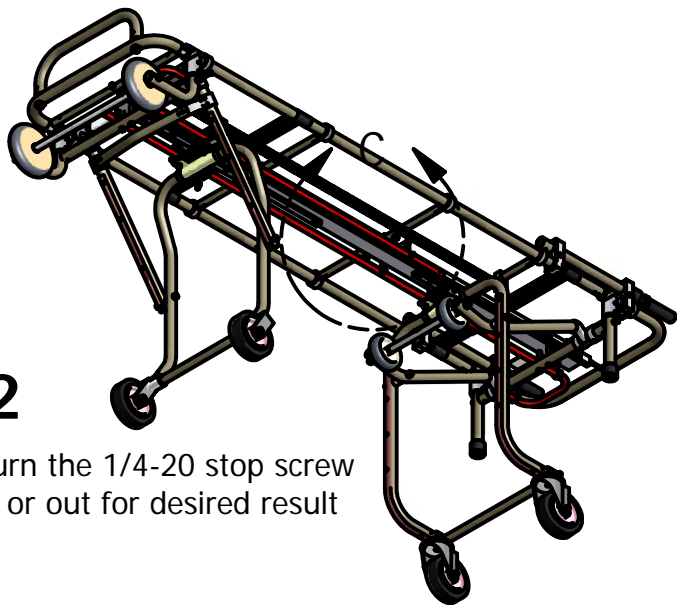

3

Note view 1- There is too much space between the lever and the slide.

WRONG
VIEW 1

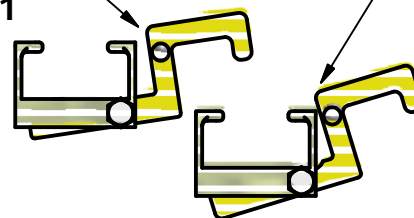

CORRECT-THE LEVER ALMOST
TOUCHES THE SLIDE
VIEW 2